

# DC FAST - DH-480V150K

## Lily - 480 VOLTS



NEMA 4R



Authorization



Management



Repairable



Outdoors

# Content

<b>1. Introduction and Safety Information.....</b>	<b>3</b>
1.1. Prefaced.....	3
1.2. Proper Usage.....	3
1.3. Intended Document User.....	3
1.4. Important Safety Instructions.....	4
1.5. Important Signs.....	5
<b>2. Product Description.....</b>	<b>7</b>
2.1. System Overview.....	7
2.2. Charging Plug System.....	8
<b>3. Technical Data.....</b>	<b>9</b>
3.1. Specifications.....	9
3.2. Function Structure of Charger.....	12
<b>4. Installation.....</b>	<b>13</b>
4.1. Required Space for Placing and Maintaining.....	13
4.2. Installation Environment.....	13
4.3. Construct Foundation.....	14
4.3.1. Concrete Foundation.....	14
4.3.2. Stainless Steel Base.....	16
4.4. Packaging and Unpacking.....	17
4.4.1. Packaging.....	17
4.4.2. Unpacking.....	17
4.5. Positioning and Wiring.....	18
4.6. Verification of Measurement Values.....	21
<b>5. Commissioning and Operation.....</b>	<b>21</b>
5.1. Power Up.....	21
5.2. Display and Usage.....	22
5.2.1. Home Page.....	22
5.3. Charging Process.....	22
5.4. Indicator Lights.....	25
<b>6. Fault Diagnosis.....</b>	<b>26</b>
<b>7. Maintenance.....</b>	<b>29</b>
7.1. Cleaning of Cabinet.....	29
7.2. Anti-Dust Net Replacement.....	29
<b>8. Contact.....</b>	<b>30</b>

# 1. Introduction and Safety Information

## 1.1. Prefaced

This manual describes the features and functions as well as installation, operation and maintenance of the Fast Charging station.

Due to the variance in technical and customer requirements, there are differences which may reflect in the maximum output power, the installed cables, plugs, and display. The components shown in this guide are all example graphics. The illustrations and explanations refer to a typical version of the device. The design of your device may differ from the description in this manual. Please read this document carefully.

## 1.2. Proper Usage

This product is a high-power charging station for recharging electric vehicles (EVs) using the fixed cable- and plug-connections CCS Combo 1/or CHAdeMO / or NACS..

When any loss or damage occurs due to improper use or unauthorized modification of the product, EVPassport shall not be liable for the product, the purchaser or third parties. The same is also valid if the guidelines for maintenance provided by EVPassport are not strictly complied with.

The installation requires planning with care and should only be carried out by qualified personnel (electricians).

## 1.3. Intended Document User

This document is intended for:

- Customers who purchased a Lily, or are in the process of ordering and want to know in more detail about installation and maintenance.
- Contractors who are responsible for site preparation and/or installation of a Lily
- Contractors who, as a qualified electrician, perform the installation, commissioning, maintenance or repair of the Lily fast charging station.
- Requirements for the electrician:
  - Knowledge of the relevant safety and accident prevention regulations Knowledge of NFPA regulations
  - knowledge of national regulations
  - Ability to recognize risks and avoid dangers

## 1.4. Important Safety Instructions



### Warning

**(Safety instructions on a risk with medium risk level! Failure to comply can result in death or serious injury)**

1. Please confirm the voltage and current level before installation.
2. The entire installation process needs to be conducted by qualified personnel.
3. Please do not operate in cloudy, rainy weather or similar conditions that may cause leakage.
4. DC charging station must be grounded properly.
5. Do not install or use the charging station closed to flammable, explosive materials or steam.
6. Without qualified personnel, do not try to open, disassemble, or modify the charging station.
7. The use of charging stations may affect or damage some medical or implantable electronic equipment, such as cardiac defibrillators, pacemakers, etc.



### Attention





**(Safety instructions on a risk with a low degree of risk! Non-compliance can lead to minor to moderate injury)**



1. Please use this product in cool and ventilated environment.
2. Before installing or cleaning the charging station, power supply must be shut down.
3. Please use the charging station within the parameters range addressed in the specifications section.
4. Do not use the charging station with non-charging purpose or others non supporting CCS or CHAdeMO charging standard vehicles.
5. If defects are found, such as cracking, wear, inoperable parts or other damage, stop using the charging station immediately and call the customer service.
6. Do not use the charging station when exposed to heavy rain, thunder, heavy snow or other severe weather conditions as this may cause damage to station and personal property.
7. Please be careful when transporting the charging station. Avoid strong external shocks. Do not drag, twist or step on the charging station to prevent damage to any parts. At any time, avoid and prevent damage to the charging station from moisture, liquids and foreign objects. Do not use if water is present or station is suspected of being damaged or corrosive. Do not touch the charging station, charging cable and charging plug with wires, tools, or other sharp objects.
8. If EV is covered by external protection hood, do not use charging station.
9. Do not start and drive your EV when socket is still connected. The user is responsible for the damage to the EV and charging station caused by improper use of charging station.

## 1.5. Important Signs

According to ISO7010 and other similar standards, the operating, warning and prohibition signs below are applied on the Lily and are also used in the manual.

These signs below are also used on the nameplate of Lily:

Warning Signs	Description
	<p><b>Grounding</b> <i>Connect to a grounding terminal</i></p>
	<p><b>General Warning Sign</b> <i>Identify a hazard which could result in damage to the operator, machinery, other equipment and / or pollution</i></p>
	<p><b>Electricity Hazard</b> <i>Warning of electrical voltage</i></p>
	<p><b>Crushing of Hands</b> <i>Touching the device may result in hand injury</i></p>
	<p><b>Cardiac Devices</b> <i>No access for people with active implanted cardiac devices</i></p>

Signs on Nameplate	Description
	<p><b>Note documentation</b>  <i>Note all documentation, which are supplied with the product</i></p>
	<p><b>WEEE Symbol</b>  <i>Do not dispose of the product with domestic waste. Please follow the valid disposal regulations in the installation site for electronic waste</i></p>

## 2. Product Description

### 2.1. System Overview

<b>a</b>	HD/Touch screen with 22.5 cm diameter (HMI)
<b>b</b>	Emergency button
<b>c</b>	Control panel with RFID/Credit card reader
<b>d</b>	Air inlet
<b>e</b>	LED Indicator
<b>f</b>	Charging plug
<b>g</b>	Cable holder
<b>h</b>	Air outlet



#### Notes:

- *All the double-plug versions intelligently distribute power between the two charging ports: the whole output power of the charger is distributed over two plugs evenly (half) or by one plug at the proper charging voltage level. For each side the output current can also be limited as requested.*

## 2.2. Charging Plug System

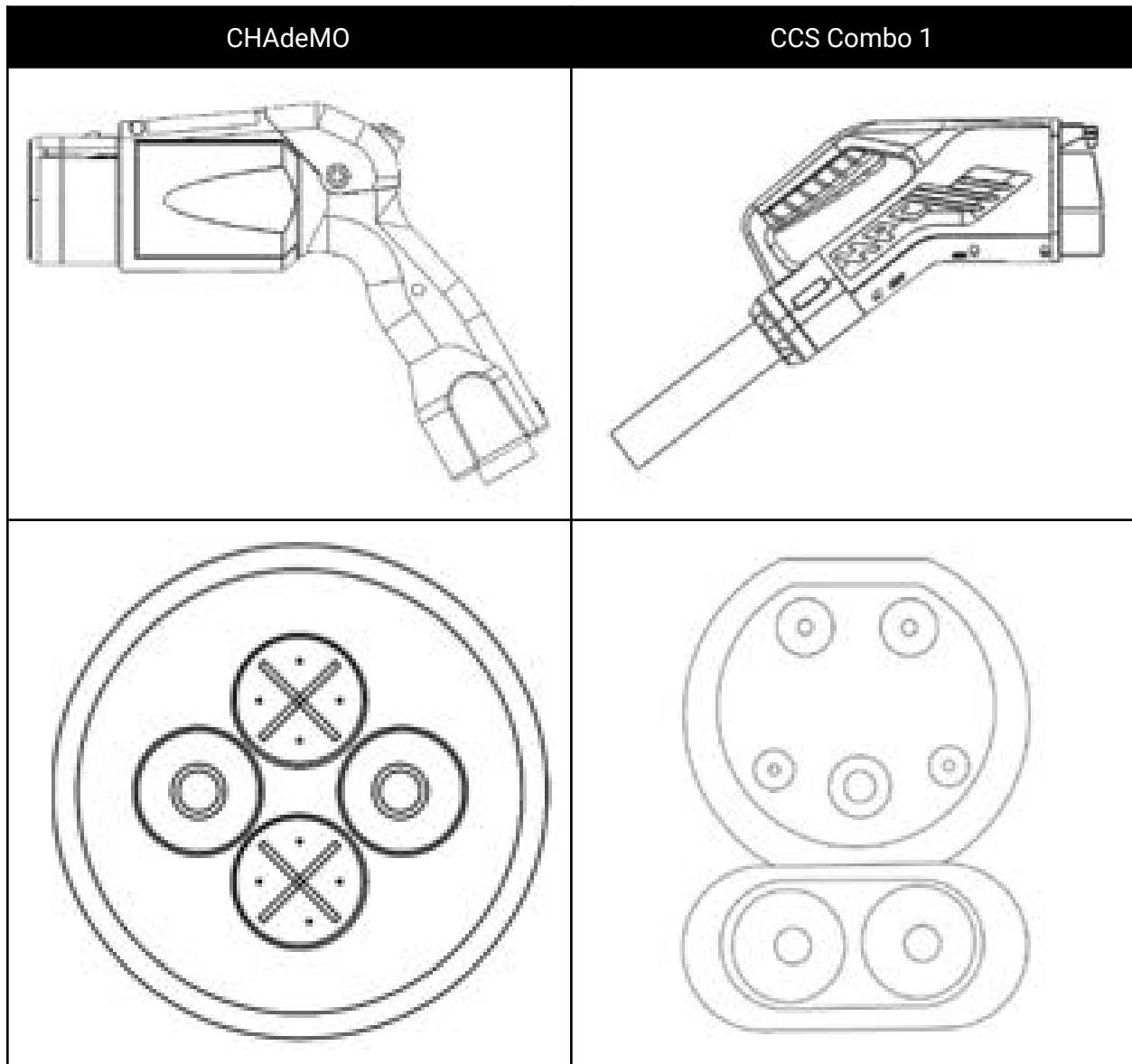



## 3. Technical Data

### 3.1. Specifications

#### Technical Specifications *(\*Copper Conductors Only)*

Maximum Output Performance	kW	150
Electrical Power Requirements	Voltage, Phase	480VAC, 3-phase, Neutral, Ground
Frequency	Hertz	60
Output Amperage	A	180
Running Load Ampacity	A	180
Minimum Circuit Ampacity	A	180
Maximum Over Current Protection	A	200A-3-Phase (NEC 625.41)
Recommended Breaker Size	A	250*
Wire size		3/0 Copper
Wiring Standard		5-Wire L1,L2,L3,Neutral,Ground
Efficiency	%	95
Power factor	%	99
Total Harmonic Distortion (THD)	%	< 5

**\*Do not exceed recommended value for breaker sizing**

#### Communication

Communication protocol	OCPP 1.6 J/S (1.6 Security & 2.0.1 ready)	
Operation system	Android	
Network connection	GPRS / 3G / 4G LTE / LAN / WIFI (optional)	
Authentication method	RFID / QR-code / Remote Command / Password/ Payment Terminal (Payter, Nayax, Ingenico)	

#### Operating Conditions

Operational temperature range	°F (°C)	-15~130 (-25~55)
Operational temperature range	°F (°C)	-40~130 (-40~55) w/ optional heat pump
Operational humidity range	%	5-95 non-condensing
Noise level	dB	< 65

#### Highlights

Remote diagnostics	Remote WebUI tool
LED and screen	LED indicators & 15-inch HD touch screen
Display content	PNG / JPG / MP4 (via screen display) & Customizable exterior color and stickers
Power Metering	AC meter with MID/ETL certificate

#### Safety characteristics

IP & IK Rating	IP54 & IK10
Residual current protection switch (RCD)	Type A
Safety protection	Over/Under voltage, Overload, Short Circuit, Anti-access, Earth leakage, Lightning, Overheat-protection
Access protection	Half cylinder lock 30/10

Station Surge Protection	Tested to IEC 6100-4-5, Level 5 (6 kV @ 3,000A). In geographic areas subject to frequent thunderstorms, supplemental surge protection at the service panel is recommended.
Standards: IEC, ISO, DIN, UL	IEC 61851-1:2011, IEC 61851-23:2014, IEC 61851-24:2014, IEC 62196-3:2014, ISO 15118, DIN 70121-2014, ISO 9001, ISO 14001:2015, ISO 45001:2018, UL2202

**Certification**

TUV (US), EEA, German Calibration Law, OCPP 1.6 & OCPP Security	CE, UL2202, Eichrecht Compliant (DE MTP 22 B 012 M), MOBI.E, be.ENERGISED
---	---

Connection standard	CCS1 / Tesla	CHAdEMO
Maximum output power	150 kW	50 kW
Output voltage range	200 - 1000 V <sub>DC</sub>	150 - 500 V <sub>DC</sub>
Maximum Over Current Protection	200 A <sub>DC</sub>	125 A <sub>DC</sub>
Connection standard	UL-62	CHAdEMO 2.0
Cable assembly length	3.2 m (Optional 5 / 7 / 10)	3.2 m (Optional 5 / 7 / 10)

**Dimensions**

External Dimensions (H x W x D)	In. [mm]	69 x 25 x 29, [1752 x 635 x 737]
Net Weight	Lbs. [kg]	871 [395]
Shipping Weight	Lbs. [kg]	1014 [460]

Connector Single / Double CCS1 or CCS1 + Tesla / CHAdEMO 2.0

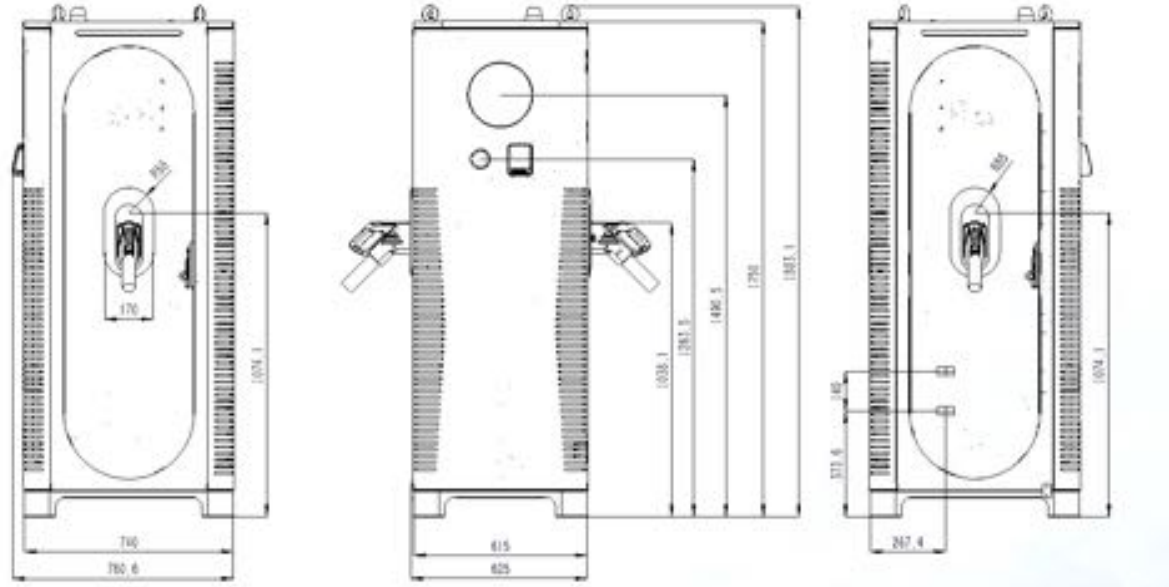

\*Dimensions in mm

### Adaptive Power Capability Overview

The Lily comes with the ability to adjust power output in accordance to a site's power availability. The function allows a unit to work with lower power sites, without any hardware changes, as well as the ability to revert/change power output post install should power availability increase through a site's lifespan. The function can be set using the included EVPassport backend, or via firmware tool during commissioning/servicing. The below table highlights the various power levels that can be set for the units, as well as the needed panel hardware to support safe and reliable operation.

<u>Power Level (kW)</u>	<u>Max Current Draw (A)</u>	<u>*Breaker Sizing (A)</u>
150	180	250 (NEC 625.41)
100	120	150 (NEC 625.41)
90	110	125 (NEC 625.41)

**\*Do not exceed recommended value for breaker sizing**

### Wire Requirement

Distance	Conduit Size	Wire Size L1,L2,L3, Neutral	Ground Wire Size
Up to 100 Feet	2-½-Inch Conduit PVC-Sch-80	3/0 -Copper Conductors	#4-Copper Conductor
Up to 200 Feet	2-½-Inch Conduit PVC-Sch-80	4/0 -Copper Conductors	#4-Copper Conductor
Up to 300 Feet	3 -Inch Conduit-PVC-Sch-80	250–kcmil-Copper Conductors	#4-Copper Conductor

- Cable type: 3P+N+PE, shielded cables are optional if required by local law.
- The optional cable shielding must be attached to the PE Rail at both ends of the cable.
- The diameter of the cable conductor must be determined by your contractor / electrician.

### UL Certification

CERTIFICATE

No. U8 118947 0001 Rev. 00

Model(s):

C6AM150JC; C6AM150CC; C6AM150CO;

C6AM120JC; C6AM120CC; C6AM120CO;

C6AM90JC; C6AM90CC; C6AM90CO;

C6AM60JC; C6AM60CC; C6AMGOCO.

TESTED ACCORDING TO:

UL2202:2009/R:2018-02

CSA C22.2 No. 107.1:2016



### 3.2. Function Structure of Charger

The figure below introduces the structure of the charger from basic to sophisticated functions:

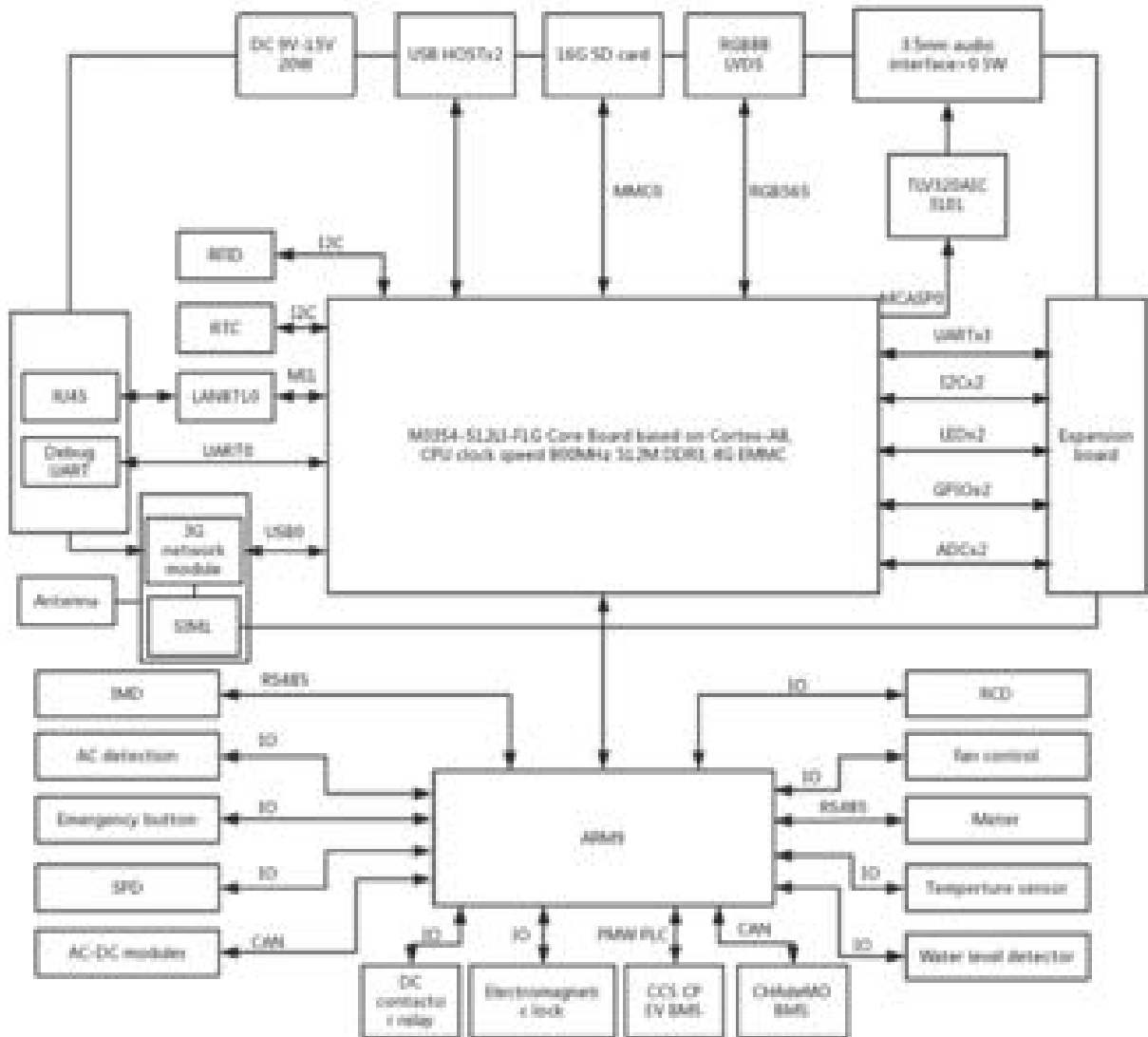

## 4. Installation

The product will be delivered to a warehouse by a logistics company and handed over to the customer. Normally EVPassport is not responsible for the transport of the charger and delivery to the final installation location.

### 4.1. Required Space for Placing and Maintaining

The space that the Lily needs is calculated as follows:

- Vertical view: 740 mm x 615mm
- Front and backside 0.8 meter to open the front door.
- Right and left 1.0 meter to facilitate maintenance personnel to replace the plug cable.

### 4.2. Installation Environment



## Warning

***Danger of life through improper installation!***

***Ignoring the environmental conditions can lead to dangerous situations when dealing with electricity.***

- When installing the charging device outside, avoid direct sunlight of the display, which will impact the ability to scan code for installation.
- Do not install and use the charging device near flammable, explosive, rough or combustible materials or chemicals or steam.

## 4.3. Construct Foundation

### 4.3.1. Concrete Foundation

The Lily charging station can be built on a concrete foundation. The flat surface of foundation should not be larger than the dimension of 800 mm \* 800 mm. For the entrance of the cable, a hole should be provided in the foundation corresponding to the type of power cable, which was dimensioned in the figure below as an example for the Lily 150kW. If you do not use a Prefabricated foundation, please notice the hardening times of the applied concrete before installation.

The height of the foundation is determined by the terrain of the site. Depending on rainfall and drainage a height between 15 cm and 30 cm above the ground is recommended by EVPassport because of frost-proof the foundation has to be about 80 cm deep under the ground.

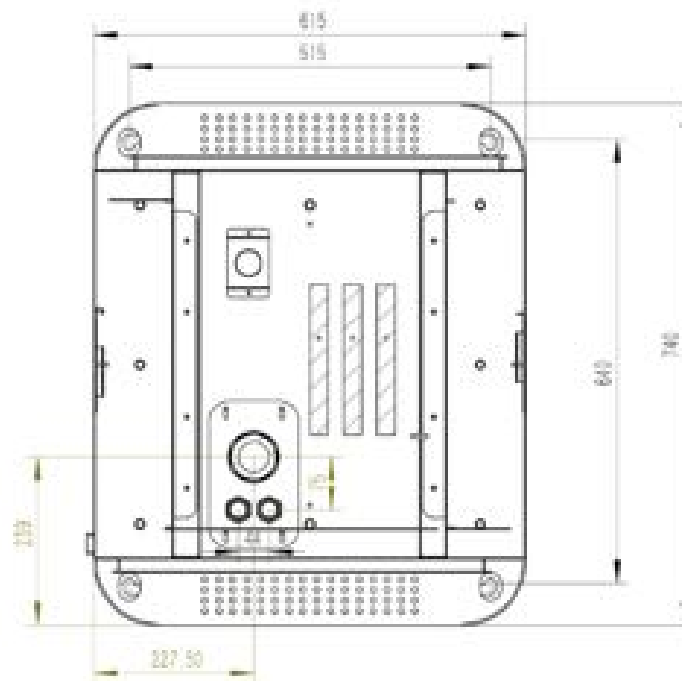

**Notes:**

- *Laying of power cables should be carried out in accordance with relevant national and industrial standards and specifications including construction quality, process and technical standards.*
- *Cable selection specification shall be selected according to the type, power, voltage and current level of the equipment and the number of equipment installed.*
- *When cables are laid, they are strictly forbidden to be exposed. Cable bridges, line pipes and directly buried cabling should be used based on the environment and installation location.*
- *When the cables are directly buried, the depth of burying shall not be less than 0.8m because of the frost-proof.*
- *When plastic pipes are used for power distribution, flame-retardant type and wall thickness >2.0mm shall be adopted. When a steel pipe is used for underground pipe wiring, the wall thickness is >2.5mm and anticorrosive treatment is carried out.*
- *The selection of power cable specifications should be selected according to the installation environment and fire requirements.*

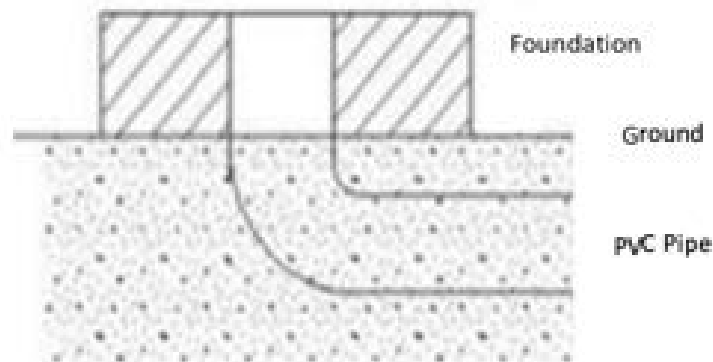

### 4.3.2. Stainless Steel Base

The Lily charging station can be fixed onto the flat ground with a stainless-steel frame. The ground shall be concrete or at equal level of hardness. Please refer to the below figures for the details of instruction.

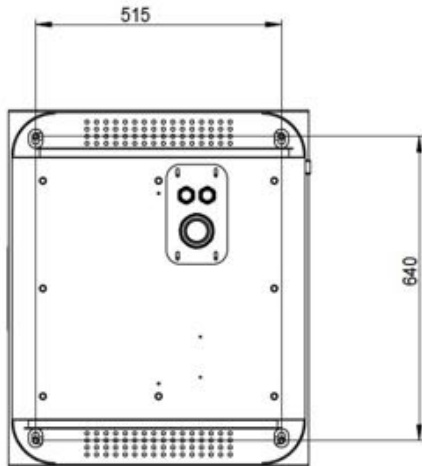

**Upper side (to be connected to the bottom of charger):**

4 x M12 bolts and 4 x M12 weld nuts  
(provided by EVPassport)

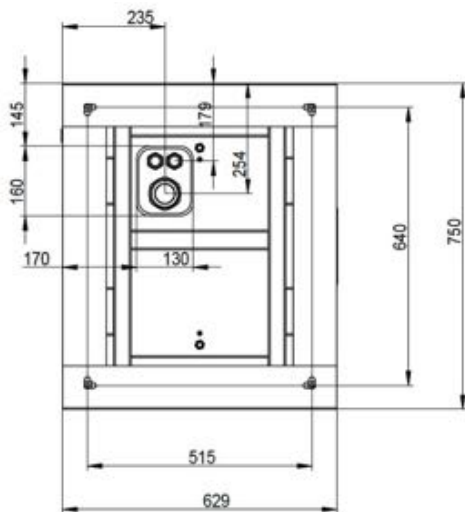

**Bottom side (to be fixed onto the ground):**

4 x M12 expansion bolts

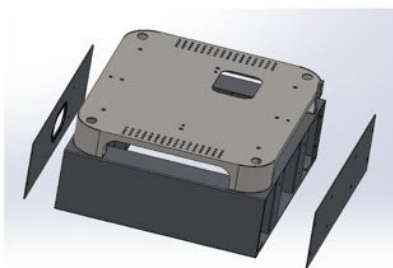

**Left and right sides (3 x removable stainless-steel plates - one with reserved hole):**

8 x M6 Philips flat head screws on each side  
(provided by EVPassport)



## 4.4. Packaging and Unpacking

### 4.4.1. Packaging

Material	Sizing	Comments
Shrink Wrap	1 Pack	Prevent Scratch
Foam Plastic Protection	2m x 2m	Prevent Shaking
Tilt Indicator	2 Set	Guarantee Upright Status
Wooden Box	0.85m x 0.9m x 2100m	
Nail Gun	1 Set	

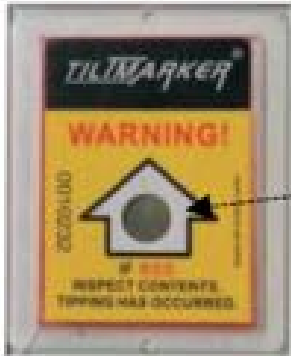

It is necessary to ensure vertical transportation. If the indicator turns red, it can be considered that during transportation severe impact and tilt occurs.

### 4.4.2. Unpacking

**Remove the package to confirm that charging station is intact:**

- Remove the outer wooden box with a crowbar
- Remove foam plastic protection
- Remove the inner shrinkwrap



## Warning

**Risk of suffocation!**

**Children are not allowed to play with plastic wrap and shrink wrap.**



## 4.5. Positioning and Wiring

### **Caution**

#### Material damage due to improper handling

- Collisions and bumps can damage the charging station.
- Move the charging station with the utmost caution.
- Please use a soft pad to set down the charging station.

Insert the forklift from the bottom facing the plug side of charging station and move the charging station to the desired installation location. As shown in the figure below the width of fork is up to 420mm and the length of fork is min. 600mm. Please move the charging station with the utmost caution!

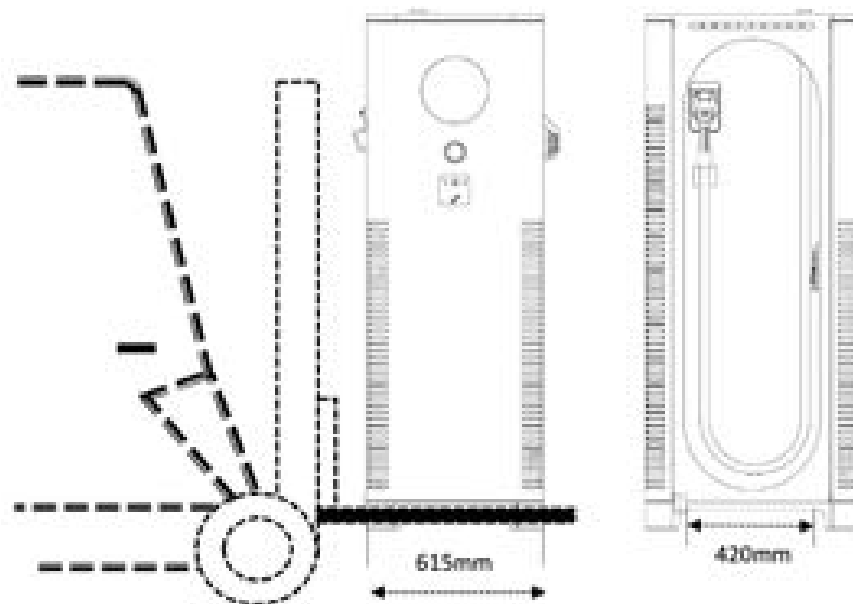

The charging station can also be transported and aligned by crane. This can be achieved through four eye-bolts included in delivery, which can be screwed into the tapped holes on the top.

The cable entrance on the bottom of the charger is divided into three inlets, of which the first is for the power cable, the second is for the LAN cable and the third is for the signal cable. In order to prevent animals from entering the charging station to cause unnecessary damage, it should be sealed with a barrier plate and three waterproof cable bushings.

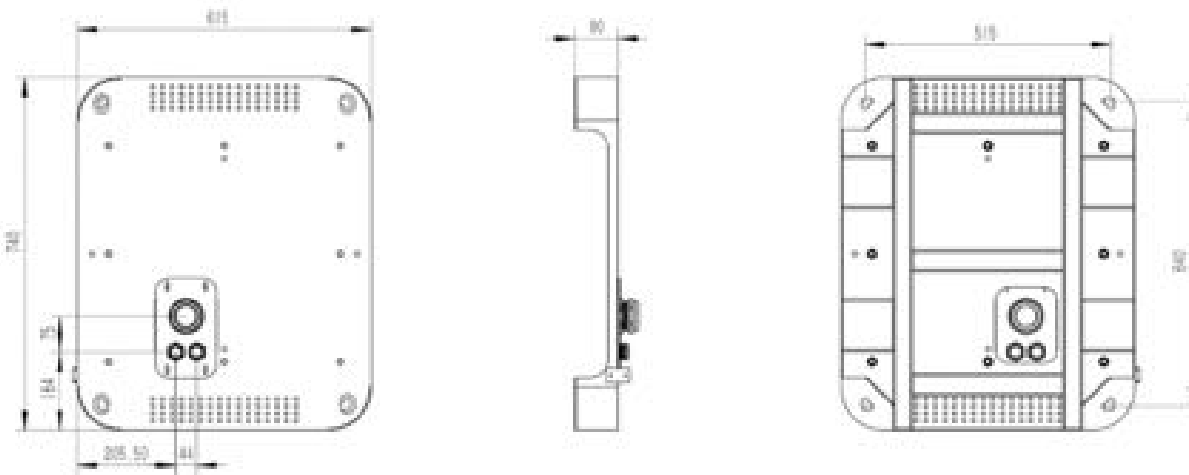

## **Caution**

### **Mortal danger due to electrocution!**

Contact with high power parts can result in electric shock, burns or death. Before working, please put on the required protection equipment such as protective clothing and gloves:

- Disconnect the system from the power supply.
- Make sure that the power supply is disconnected before and while working on installation.

After opening the front door and removing the cover, connect the 3 phase cables L1, L2, L3 and the neutral conductor N as well as the PE protective conductor to the busbar. Then check the connection carefully. Tighten all terminal screws to complete the installation of the power cables. The screw size and torque requirements are shown below in the table below.

Type	Size of Screws	Torque	Tools
Lily 150kW(480V)	L1/L2/L3/N M10x20mm PE M8x16mm	M8: 15-20N.m M10: 25-30N.m	13mm socket for M8; 17mm socket for M10

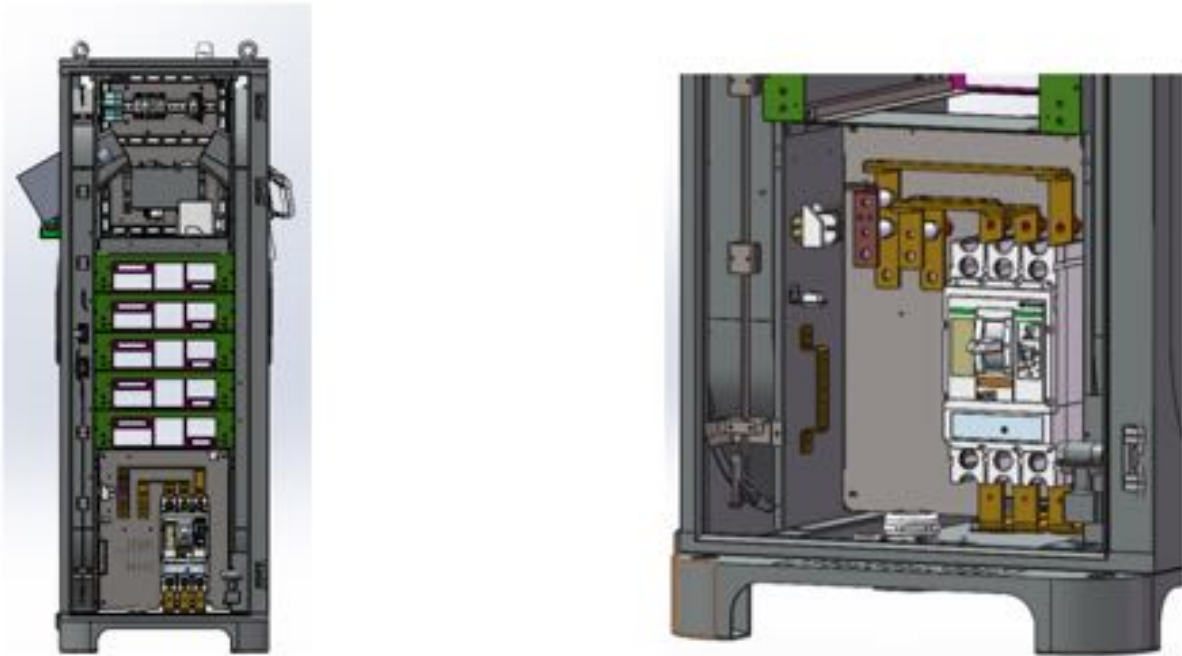

In case that the station will be connected with a LAN cable for the backend connection, this cable should be laid through a waterproof gland on the bottom to the RJ45 Port on the A8 communication board, shown in the figure above (it's suggested to use such soft flat LAN cable like in figure because of the limited place for installation. Any other RJ45 converter in the charger could be installed by customer if needed)

In case that the station connects with the backend through SIM card, the SIM card slot shown in the figure below can be used. (only for standard SIM card size 15x25mm).

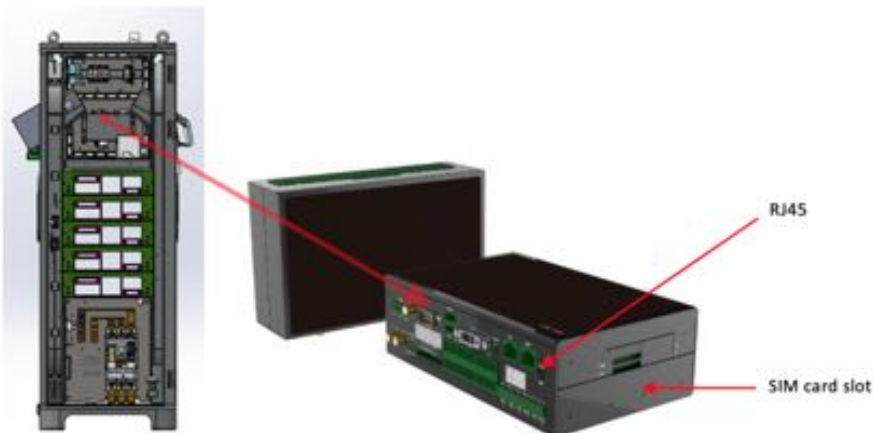

After installing the cable into the charging station, the bottom of the charging station is fixed to the concrete platform by 4 fixed concrete anchor screws M10.

## 4.6. Verification of Measurement Values

Please ensure all measured values are within specified range before proceeding to commissioning and operation.

### Measurement in 480Vac:

Measurement Points on Live Side	Unit	Nominal Value	Specified Range
L1 to N	Voltage	277 V	± 10%
L2 to N	Voltage	277 V	± 10%
L3 to N	Voltage	277 V	± 10%
L1 to L2	Voltage	480 V	± 10%
L1 to L3	Voltage	480 V	± 10%
L2 to L3	Voltage	480 V	± 10%
N to PE (on connection terminal)	Voltage	0 V	
PE to N (on connection terminal)	Resistance	<1000m Ω in TN-S system	Variable according local law/standards and different earthing system

## 5. Commissioning and Operation

### 5.1. Power Up



## Warning

### Mortal danger due to electrocution!

Contact with high power parts can result in electric shock, burns or death.

If the charger is firmly fixed on the foundation and the power supply has been properly applied, then the charging station can be powered up by turning on the main switch, which is located on the bottom left behind the front door.

Once the charger has been powered on, the charger operates automatically, and loads the operating system, ready to use in about two minutes.

## 5.2. Display and Usage

### 5.2.1. Home Page

This is the home page on screen after the charger is powered up:

**Touch Screen**



**Non-Touch screen**



## 5.3. Charging Process

The charging flow chart for Lily with touch Screen:

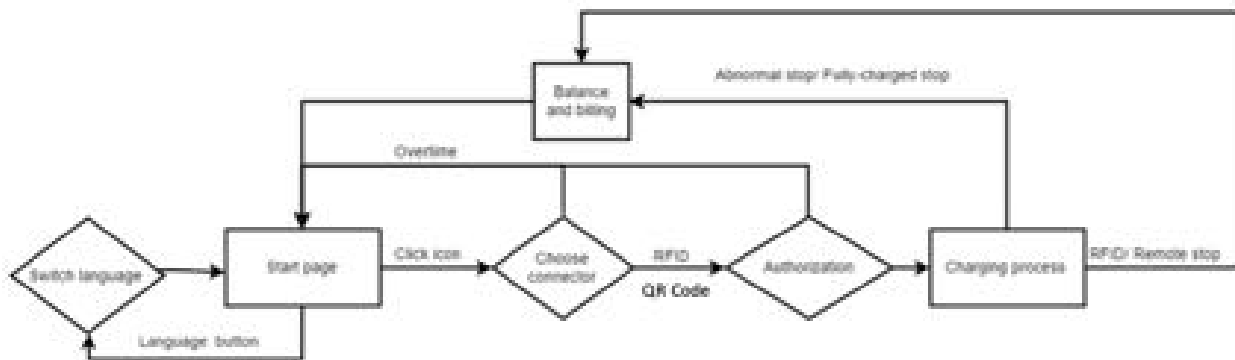

The charging flow chart for Lily with Non-Touch Screen:

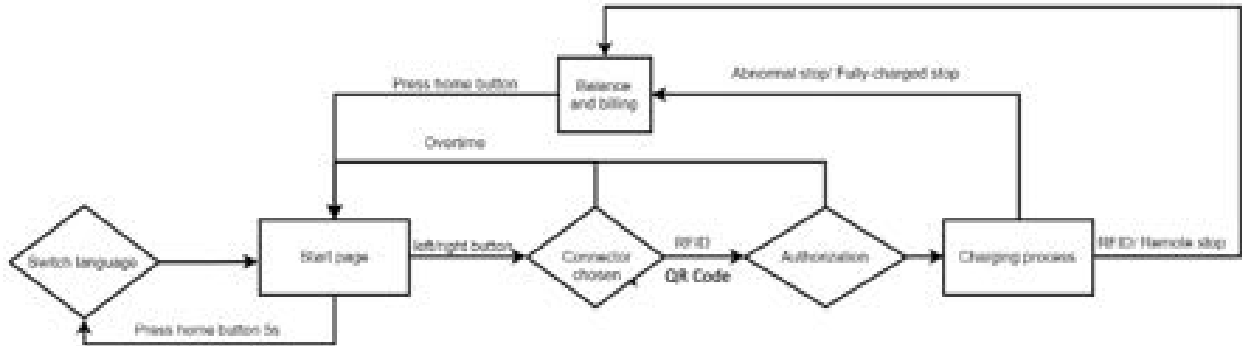





**The explanation of keywords:**

- **Icon:** the charging plug sign on screen;
- **Overtime:** There is no action or no proper operation from the user within specified time;
- **RFID:** Radio Frequency Identification card;
- **Abnormal stop/ fully-charged stop:** stop initiated by EVSE or EV;
- **RFID/Remote stop:** stop initiated by user.
- **Language button:** press question mark in the bottom right corner (just available for touch screen) and then the different languages can be selected shown in the Settings Page to the right.



Settings Page







The important steps are shown below as screenshots in the table (for single-plug version just one plug icon is shown on the screen and all the others are same as double plug):

Touch Screen	Steps
	<p>1. Select charging icon and wait for the authentication</p>
	<p>2. Authentication passed, waiting for the official charging process</p>
	<p>3. Charging process</p>
	<p>4. The bill after charging</p>
<p>5. Press "OK" to complete this charging process</p>	



## 5.4. Indicator Lights

Above the respective cable suspension is a widely visible LED indicator, which shows different statuses of the charging station.

Lights outline	Status
	Sleep mode
	Charging percentage
	Fully -charged
	System activation
	Error
	System self-checking

## 6. Fault Diagnosis

- Charging station is equipped with an automatic diagnosis function, and the fault will be directly displayed on the screen and sent to the backend.
- If the charging station is online, users can call customer service, we will arrange an online engineer for remote repair charging fault.
- If the charging station does not connect to the network, please call customer service, and we will arrange a crew to repair and maintain it as soon as possible.

Error Code	Meaning	First-Aid Checking	Responsibility
<b>A0101</b>	Charger communication failed Communication between A8 and DCB failed	Check hardware connection between A8 and DCB	EVSE
<b>A0104</b>	Power module communication failed or power module is not connected	Check that the DIG switch of the module is in the correct position, Check the CAN communication connection between power module and DCB module	EVSE
<b>A0103</b>	Meter for Plug 1/Plug 2 warning	Check the connection and communication of electricity meter 1/2 (RS485)	EVSE
<b>A0105</b>	Insulation module alarm	Check insulation module power supply Check insulation module connection and communication (RS485)	EVSE
<b>100F</b>	Charger temperature alarm	Check ventilation system, dust filter and ventilation fan	EVSE
<b>1012</b>	BMS demand voltage is above or below limits	Check EV	EV
<b>1013</b>	L1-phase overvoltage	Check grid input	Grid
<b>1014</b>	L1-phase undervoltage	Check grid input	Grid

<b>1015</b>	L2-phase overvoltage	Check grid input	Grid
<b>1016</b>	L2-phase undervoltage	Check grid input	Grid
<b>1017</b>	L3-phase overvoltage	Check grid input	Grid
<b>1018</b>	L3-phase undervoltage	Check grid input	Grid
<b>1023</b>	Discharge check failure	Check power module	EVSE
<b>1025</b>	Insulation check failure	Please contact EVPassport	EVSE
<b>1080</b>	Power module check failure	Please contact EVPassport	EVSE
<b>10A0</b>	SPD warning	Check SPD status	EVSE
<b>10B0</b>	PE warning	Check PE connection	EVSE
<b>2005</b>	Plug 1 temperature alarm	Check status of plug 1	EVSE
<b>2006</b>	Plug 2 temperature alarm	Check status of plug 2	EVSE
<b>2016</b>	Plug DC contactor failure	Check plug DC contactor status	EVSE
<b>2017</b>	EV battery reverse wiring	Check EV	EV
<b>2018</b>	EV battery voltage abnormal	Check EV	EV
<b>2019</b>	EV battery overvoltage	Check EV	EV
<b>2021</b>	EV battery undervoltage	Check EV	EV
<b>4002</b>	The emergency stop button is pressed	Check the cause of emergency stop, restore emergency button	Unknown
<b>4009</b>	Switch DC contactor failure	Check switch DC contactor status	EVSE
<b>4021</b>	Charger front door opens	Check whether the door is closed, check whether the access control spring is working and whether the cable is connected	EVSE

<b>4022</b>	Charger back door opens	Check whether the door is closed, check whether the access control spring is working and whether the cable is connected	EVSE
<b>4023</b>	Power module failure	Please contact EVPassport	EVSE
<b>4025</b>	The vehicle demand voltage exceeds power module rating	Check EV	EVSE
<b>4026</b>	Electromagnetic lock locking failure	Please contact EVPassport	EVSE
<b>4027</b>	Electromagnetic lock unlocking operation failed	Please contact EVPassport	EVSE
<b>4028</b>	Electromagnetic lock reset failed	Please contact EVPassport	EVSE
<b>5009</b>	The power module is not energized	Check power module supply	EVSE
<b>5010</b>	Power module address conflict	Check if the DIG switch of the module is in right position	EVSE
<b>5011</b>	PE warning	Check PE connection	EVSE
<b>5012</b>	AC wiring of charger lacks phase	Check three phase connection	EVSE
<b>6003</b>	Water level alarm	Check if there is water exceeds detector	EVSE
<b>6004</b>	Relay check failure	Check relay	EVSE
<b>6005</b>	Electromagnetic lock check failure	Please contact EVPassport	EVSE

**Notes:**

*When scanning QR-code or sweeping NFC/RFID card to start charging and system shows self-test failure: due to the difference of EVs inlets, plug the socket again to ensure that the charging plug is in the right position and lock functions well.*

## 7. Maintenance



### Warning

#### **Mortal danger due to electrocution!**

The contact with high power parts can result in electric shock, burns or death. Before working, please put on the required protection device such as Protective clothing and gloves:

- Disconnect the system from the power supply.
- Make sure that the power supply is disconnected while working.

Make sure to put the charging plug back on the right side of the plug holder after charging and ensure that the charging cable is naturally drooping.

Regularly check the charging station and charging cable. If damage is found, you can contact the customer service for replacement or maintenance.

### 7.1. Cleaning of Cabinet

- The Lily Charge Station is powder coated. This coating must be kept in good condition;
- We suggest that Lily needs to be cleaned two times every year (adjusted according to the actual situation);
- Remove rough dirt by spraying with low-pressure tap water instead of high-pressure jet;
- Apply a neutral or weak alkaline cleaning solution and let it soak;
- Only use cleaning agents with a PH value between 6 and 8;
- Do not use cleaning agents with abrasive components;
- Do not use abrasive tools;
- Remove dirt by hand with a non-woven nylon hand pad;
- Do a regular check on the coating for damage;
- Call the customer service if any damage on coating occurs.

### 7.2. Anti-Dust Net Replacement

In order to change the anti-dust net in 10min, quick change method is applied. After opening the front door and lifting the lock bar, the cover will open, then wash, air-dry the net, install the anti-dust net and lock back.

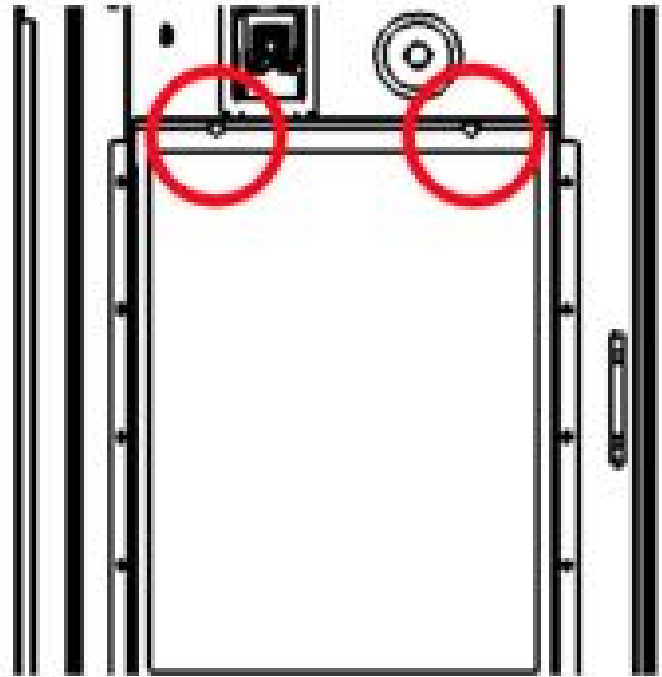

## Warning

### **Danger of life!**

Please shut down the input power before cleaning the charging station.

When opening the front and rear doors, please pay attention to prevent dust from entering the cabinet and clean if necessary.

## 8. Contact

EVPassport Inc  
1629B Electric Ave  
Venice, CA 90291

**Email:** [Support@EVPassport.com](mailto:Support@EVPassport.com)